

# EM N2 512

BUILT FOR  
PERFORMANCE

INDUSTRY-LEADING  
LOW-LIGHT SNR, BALANCING  
SPEED AND FIELD OF VIEW

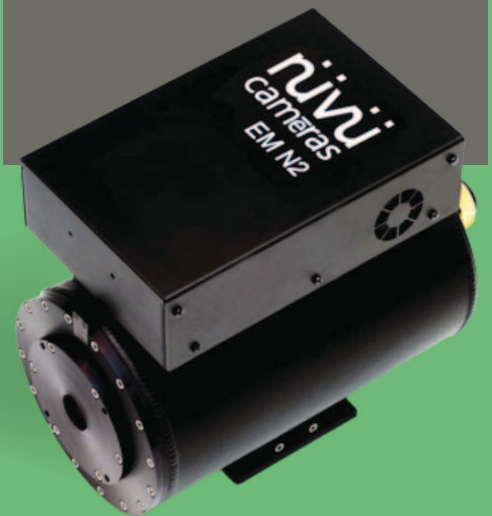

## RETHINK EMCCD

## A NEW STANDARD FOR LOW LIGHT IMAGING

### OUTSTANDING SNR THANKS TO

Patented electronics eliminating inherent EMCCD camera noise for true photon counting imaging

Lowest background signal and highest electron-multiplying (EM) gain, up to 5000, in inverted mode of operation (IMO) for optimal results in ultra low-light conditions

Optimal on-chip thermoelectric cooling for minimal background signal and stabilized EM gain

Made for applications requiring the ultimate sensitivity for the fields of Space and Defense, Life Science, Physics, Industrial and more.

ULTIMATE SENSITIVITY enabling highly efficient low-flux imaging, with frame rates exceeding 33 fps in full frame at 10MHz readout rate

SUPERIOR IMAGE QUALITY thanks to greater charge transfer efficiency

NO NOISE-FILTERING ALGORITHMS the amount of noise generated is simply lower, eliminating the risk of removing genuine photoelectrons

VERSATILITY to choose between EM or Convention CCD output to best match your acquisition requirements

### PHOTON COUNTING PERFORMANCES COMPARISON

- EM N2 512 (All specifications measured in IMO)
- Best achievable performance with other EMCCD cameras

(Other manufacturers do not specify the mode of operation – IMO or NIMO – used to measure one specific characteristic. These are two mutually exclusive EMCCD operation modes whose benefits cannot be combined.)

At least 15% more genuine photons counted

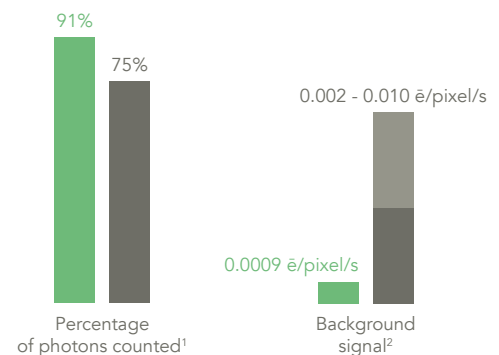

Figure 1  
EM N2 512 benefits for Photon Counting imaging

# SIMPLE INTEGRATION INTO A WIDE VARIETY OF SOFTWARE SYSTEMS

Nüvü Camēras offers the highest standard of EMCCD technology in a compact liquid nitrogen cooled camera. The technology at the heart of the EM N2 was originally designed for space exploration, where the need for state-of-the-art instruments drives innovation. Now optimized and extended to a broad range of applications, the user-friendly EM N2 provides many advantages to efficiently bridge the gaps between purchase, setup, discoveries, and publications.

- › NüPixel control, acquisition and analysis software
- › Software development kit (SDK) for customizable programming
- › Windows & Linux Compatibility
- › Various drivers available for commercial software
- › Worldwide professional customer support

*Consultation services are available on demand.*

## EM N2 512

CHARACTERISTICS	SPECIFICATIONS
Digitization	16 bits
Electron-multiplying gain	1 - 5000
On-chip temperature stabilization	± 0,01°C
Minimum cooling temperature <sup>3</sup>	-110°C
Quantum efficiency	> 90% at 600 nm (see Fig. 2)
EM register pixel well depth <sup>4</sup>	800 kē
Spectral range	250 - 1100 nm
Triggering	Internal or external Selectable signal polarity
Timestamp resolution	4 ns
Readout noise through	EM < 0.1 ē @ 10 MHz Conv 3 ē @ 100 kHz
Vertical clock speed	EM 0.3 – 5 μs Conv 0.3 – 5 μs
Dark current <sup>5</sup>	0.0001 ē/pixel/s
Charge transfer efficiency <sup>6</sup>	> 0.999993
Single photon detection at 10MHz probability (EM gain = 5000)	> 91%
Imaging area	512 × 512 pixels 16 μm × 16 μm pixel area 8.19 mm × 8.19 mm effective area

Table 1 EM N2 512 general characteristics and specifications

### FEATURES

EM gain range of 1 – 5000

Lowest clock-induced charges levels (CIC)

Patented technology optimized for true photon counting

Highest horizontal charge transfer efficiency

Ultimate cooling performance

Highest quantum efficiency

Selectable output

mROI

Cropped-sensor mode

Low latency

External trigger modes

### BENEFITS

Lowest effective readout noise  
Unmatched single photon detection capabilities

Highest SNR as a result of lowering the CIC, the dominant noise source of EMCCDs

Linear and photon counting modes are available in EM operation

Clearer images  
No pixel leaking

Negligible dark noise  
Superior charge transfer efficiency

Best sensitivity available thanks to back-illuminated grade 1 EMCCD detector (see Fig. 2)<sup>7</sup>

Fast and easy switching between conventional CCD and EMCCD operations

Select multiple customizable regions of interest on the detector to increase acquisition rates

Faster acquisition rates for a region of interest by masking part of the EMCCD detector<sup>8</sup>  
Greater acquisition versatility using customizable size and position for the cropped region of interest

Low Latency between end of exposure and 1<sup>st</sup> pixel

Multiple modes available to optimize versatility on frame rate

Table 2 EM N2 512 features and benefits



## WHEN EVERY PHOTON COUNTS

The EMCCD technology is perfectly suited for low-light applications requiring minimal background noise due to its negligible effective read-out noise enabled through high EM gain. In linear mode of operation, the EM gain cannot be precisely determined on a per-pixel basis because of its stochastic nature. It however generates an excess noise factor (ENF) that, for high EM gains, leads to a degraded SNR. In fact, it affects the SNR the same way halving the quantum efficiency would. With photon counting (PC) mode of operation, Nüvü Cameras efficiently suppresses the ENF, thus allowing single photon sensitivity.

Nüvü™'s ultra-sensitive cameras successfully operate in PC mode thanks to their high EM gains and minimal background noise. Although attaining large EM gains is simple, the electron-multiplying process entails more clock-induced charges (CIC), a dominant EMCCD noise source. The innovative electronics driving EM N2 cameras virtually eliminates CIC and lowers the total background signal while providing the highest gain on the market. The results: better data in low lighting conditions.

## EM N2 512 MODEL

SPECIFICATIONS	EM N2 512
Max frame rate <sup>3</sup> (Frames per second)	33.6
Readout rate through EM channel (MHz)	10
Readout rate through Conventional channel (MHz)	0.1,1,3
Typical clock-induced charges <sup>9</sup> (Electron/pixel/frame)	0.0009

Table 3 EM N2 512 model specifications

## FASTER FRAME RATE FOR SENSITIVE IMAGING

Crop mode included for applications requiring higher readout rates.  
Other readout speeds and frame rates are also available, as are different EMCCD detector sizes.

MODEL	REGION OF INTEREST				
	512 × 512	512 × 256	512 × 124	512 × 64	512 × 32
EM N2 512	33.6	66.7	130	250	454

Table 4 EM N2 512 frame rates at maximum readout rate

## Features

FOR FASTER ACQUISITION:

- › Crop Mode
- › Fast Kinetics Mode
- › Time-Delay Integration (TDI) Mode
- › Multiple Region of Interest (mROI) & ROI

FOR MORE VERSATILITY:

- › UV solutions

# QUALITY PRIORITY

All parts are treated in compliance with high vacuum requirements, including all metal sealed in a Class 10,000 cleanroom to ensure the best cooling performances without maintenance.

## COMPUTER REQUIREMENTS:

- › Communication interface: PCIe Camera Link (min. x1)
- › Operating system: Windows and Linux (Ubuntu)

## CAMERA ENVIRONMENT:

- › Operating temperature: 0°C to 30°C
- › Humidity: < 90 % (non-condensing)
- › Power Input: 100 – 240 V, 50 – 60 Hz, max. 3 A

## TECHNICAL DRAWINGS

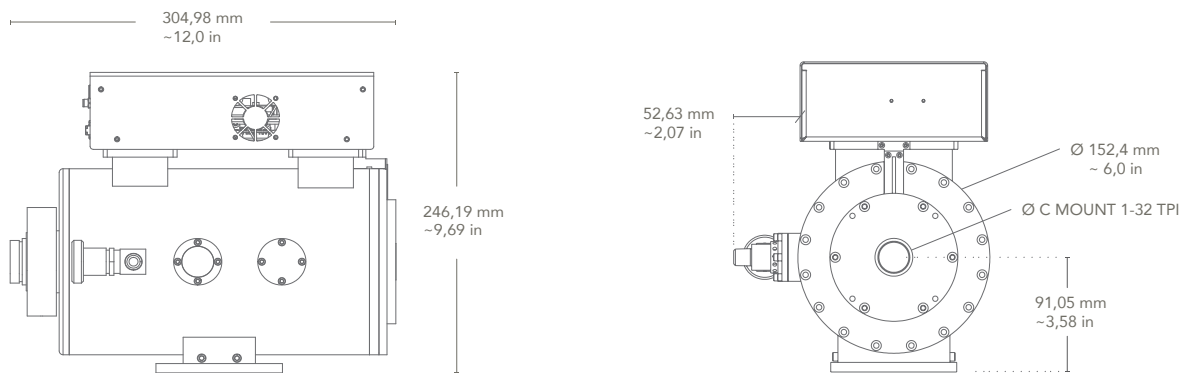

- 1 Detected events with signal 5 times greater than readout noise in photon counting mode. Measured data.
- 2 Expected signal level at an EM gain of 1000 at minimum cooling temperature via air cooling and maximum frame rate in continuous exposure at 10 MHz.
- 3 At maximum horizontal speed, full frame readout.
- 4 As per the EMCCD detector manufacturer's datasheet. Other configurations may exist.
- 5 Typical values measured at -95°C. These numbers may vary depending on the EMCCD detector.

- 6 Mean horizontal charge transfer efficiency measured with an EM gain of 1000 at -85°C and 10 MHz readout rate.
- 7 Nüvü gives only the specifications of the EMCCD detector's manufacturer for grade 1 sensors (e.g. Quantum efficiency, aesthetic specifications, blemishes).
- 8 Optical mask not included.
- 9 Typical signal level at an EM gain of 1000 at -95°C and maximum frame rate in continuous exposure at 10 MHz.

## TYPICAL QUANTUM EFFICIENCY

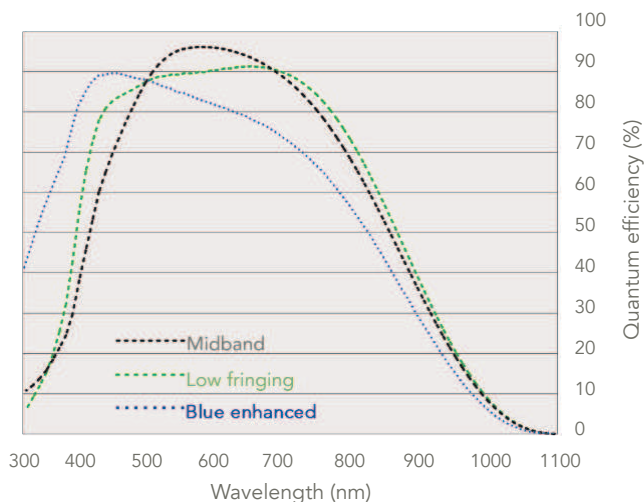

Figure 2  
Typical spectral response as a function of wavelength, as specified by the EMCCD detector manufacturer

Contact us at:  
[info@nuvucameras.com](mailto:info@nuvucameras.com)  
 +1 514 733 8666  
 Montreal (Quebec)  
 CANADA



EM N2 and NüPixel are the intellectual property of Nüvü Camēras. All other brands are properties of their respective owners. Incremental changes are made to the products and specifications are subject to modification without prior notice.  
 EM N2 512 Specification Sheet 2.2.3  
 © Nüvü Camēras, 2025

[www.nuvucameras.com](http://www.nuvucameras.com)